

TORNADO

By Duraquip

3 COMPARTMENT SPECIFICATIONS

GA DRAWING / HOPPER SPLITS

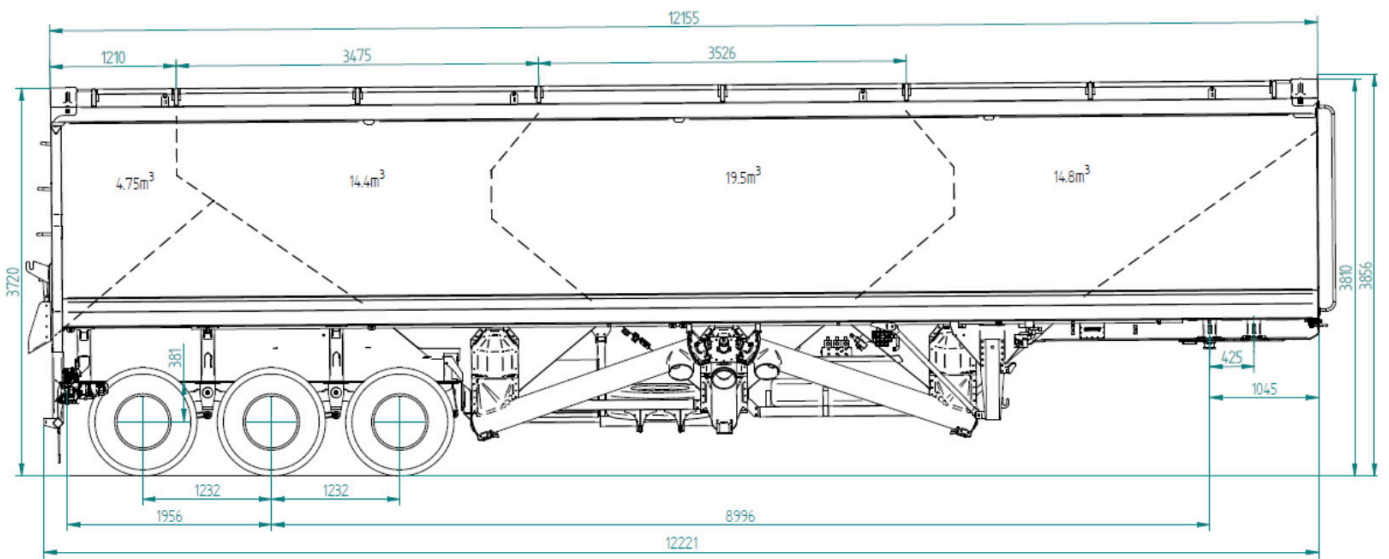

HOPPER CAPACITIES

TOTAL	53.4m ³	WHEAT	BARLEY	FERTILISER	UREA
HOPPER 1	14.8m ³	11.84T	10.36T	14.8T	10.36T
HOPPER 2	19.5m ³	15.6T	13.65T	15.6T	13.65T
HOPPER 3	14.4m ³	11.52T	10.08T	14.4T	14.4T
REAR	4.7m ³	3.76T	3.29T	4.7T	3.29T
TARE WEIGHT 9.4T					

SUB-FRAME COLOURS



Call our knowledgeable sales team today to discuss the TORNADO and which model will best suit your operations!



1800 27 1800 | sales@duraquip.com.au